

MULTIMAX MACHINES CAN BE MADE:  
 WIDER OR NARROWER THAN SHOWN  
 WITH MORE OR LESS TRAVEL THAN SHOWN  
 OPPOSITE HAND THAN SHOWN  
 WITH OR WITHOUT A WORK SURFACE  
 WITH WATER TABLES, DOWN DRAFTS, DRY TABLES  
 WITH ROLLER CONVEYOR WORK TABLES  
 WITH SHUTTLE TABLE CARTS SYSTEMS  
 WITH DROSS REMOVAL TABLE SYSTEMS  
 WITH MORE OR CLEARANCE THAN SHOWN  
 WITH UP TO 4 PLASMA TOOL STATIONS  
 WITH UP TO 8 OXY-FUEL STATIONS  
 WITH POWER TRACK SYSTEM OVER-HEAD  
 WITH TUCKED LENGTH AXIS RAILS  
 UNITIZED WITH CUTTING SURFACE  
 WITH CUSTOMER SPECIFIC OPTIONS

**CUSTOMERS RESPONSIBILITIES**

- MOUNTING OF "Y" AXIS RAIL
- INSTALLATION OF ELECTRICAL PANEL
- INSTALLATION OF HOSE AND CABLE CARRIER
- TERMINATION OF ELECTRICAL SERVICE TO ELECTRICAL DISCONNECTS
- TERMINATION OF GAS SUPPLIES TO THE MACHINE & PLASMA SYSTEMS
- SUPPLY AND INSTALLATION OF WATER OR CUTTING TABLE
- SUPPLY PLASMA WITH DESIRED CUTTING & SHIELD GASES
- SUPPLY SHOP AIR AND OXY-FUEL HOISING TO MACHINE THROUGH CABLE CARRIER SYSTEM.
- SUPPLY ALL TOOLING CONSUMABLES FOR START-UP & TRAINING

NOTE:  
 ALL GAS AND ELECTRICAL INSTALLATIONS MUST BE  
 IN ACCORDANCE WITH STATE AND LOCAL CODES.

NOTE:  
 IT IS THE CUSTOMERS RESPONSIBILITY TO ASSURE THAT THE SUPPLY  
 VOLUMES OF THE OXYGEN & THE FUEL GAS IS LARGE ENOUGH TO  
 SAFELY SUPPORT MAX. CUTTING CAPACITY PER TORCH USED.

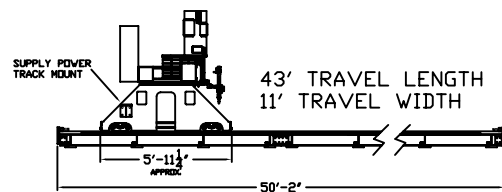

ALL DIMENSIONS ARE APPROXIMATED. DUE TO ASSEMBLY TOLERANCES AND INSTALLATION PROCEDURES, ANY FINAL DIMENSIONS COULD VARY SLIGHTLY. IF FOR ANY REASON ANY DIMENSION MUST BE HELD TIGHT, THE CUSTOMER MUST NOTE IT ON THE APPROVAL.

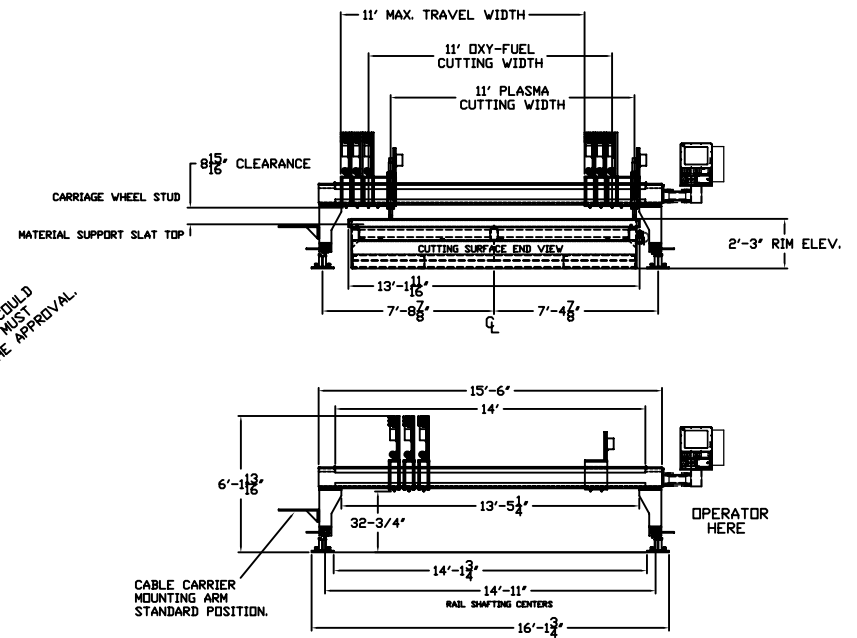

REV	DESCRIPTION	BY	DATE	© CONTROLLED AUTOMATION, INC. BRYANT, ARKANSAS	TITLE: 10' X 43' MULTIMAX MACHINE 3 OXY - 1 PLASMA	SCALE: NTS	DATE: 4/30/08	JOB NUMBER:	
						DRAWN BY: JAR	REF. DWG.:	DRAWING NUMBER:	REV: