

**CUSTOMER RESPONSIBILITIES**

- INSTALLATION OF "Y" AXIS RAILING SYSTEM
- LOCATING & PLACEMENT OF ELECTRICAL PANEL
- ASSEMBLY OF HOSE AND CABLE CARRIER FLEX TRACK SYSTEM
- PROVIDE ELECTRICAL SERVICE & WIRE TERMINATION TO PROVIDED DISCONNECTS
- PROVIDE ALL PLUMBING SERVICES & PLUMBING TO SUPPLY POINT OF MACHINE
- PLUMBING GASES MUST BE LARGE ENOUGH TO SAFELY SUPPORT MAXIMUM MATERIAL PROCESSING
- SUPPLY AND INSTALLATION OF MATERIAL SUPPORT SURFACE
- SUPPLY ADEQUATE & SAFE MATERIAL FIXTURING FOR ENTIRE MATERIAL THICKNESS RANGE & TYPES
- PROVIDE COOLANT FOR DRILLING OPERATION
- SUPPLY ALL TOOLING FOR CUTTING AND DRILLING THAT WILL BE NEEDED FOR STARTUP, TESTING, & TRAINING

**NOTE:**

ALL GAS AND ELECTRICAL INSTALLATIONS MUST BE IN ACCORDANCE WITH STATE & LOCAL CODES

**SYSTEM OPTIONS:**

- AUTO-GAS OXY-FUEL TORCH SYSTEM
- HPR260 AUTO-GAS PLASMA SYSTEM W/ COMMAND THC
- AUTOMATIC CONTROL 10 HP HIGH SPEED DRILL ASSEMBLY
- ARC WRITER MARKING & LIFTER ASSEMBLY
- EMERGENCY PARTS KIT
- OFFICE SEAT OF CADNESTING PRO WITH TRUE SHAPE NESTING
- WATER TABLE MATERIAL CLAMPING KIT
- DRAWING PACKAGE FOR CUSTOMER FAB WATER TABLE & MATERIAL CLAMP SYSTEM

THE SERVICE PANEL AND PLASMA COMPONENTS ARE TO BE WITHIN 15' FROM THE CENTER OF THE LENGTH AXIS OF TRAVEL.

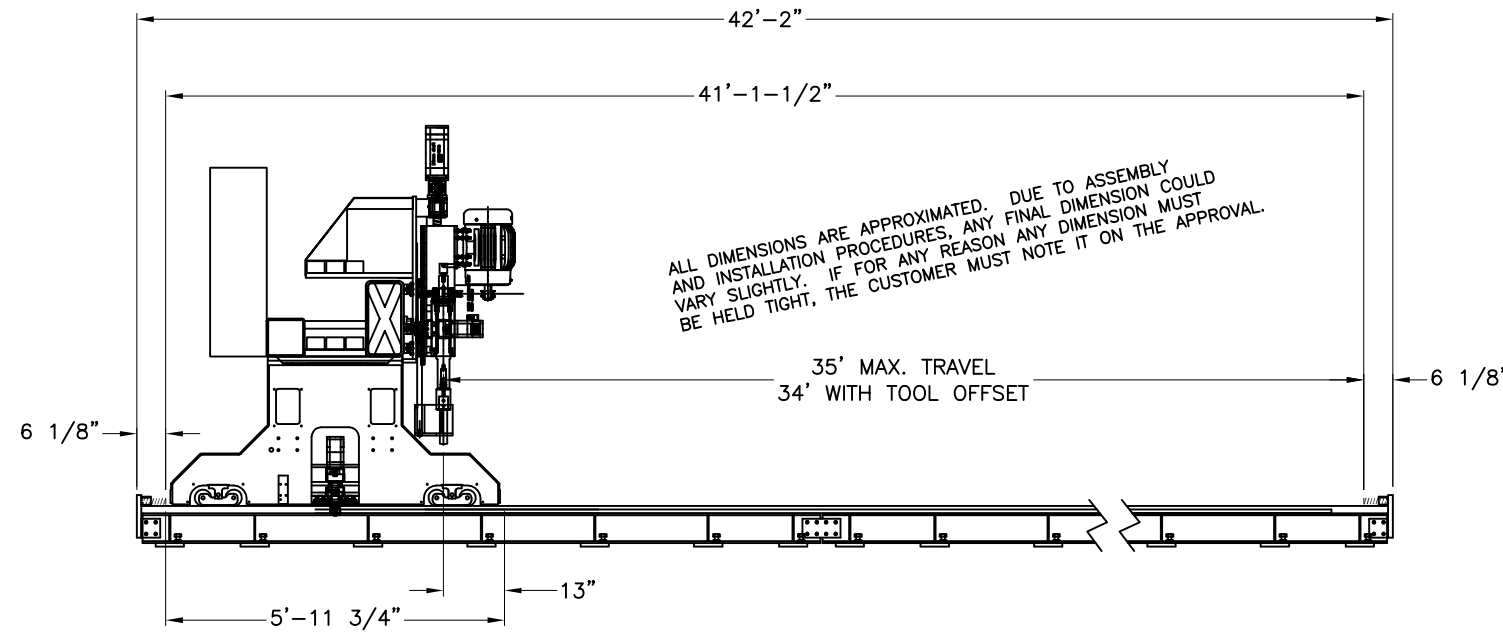
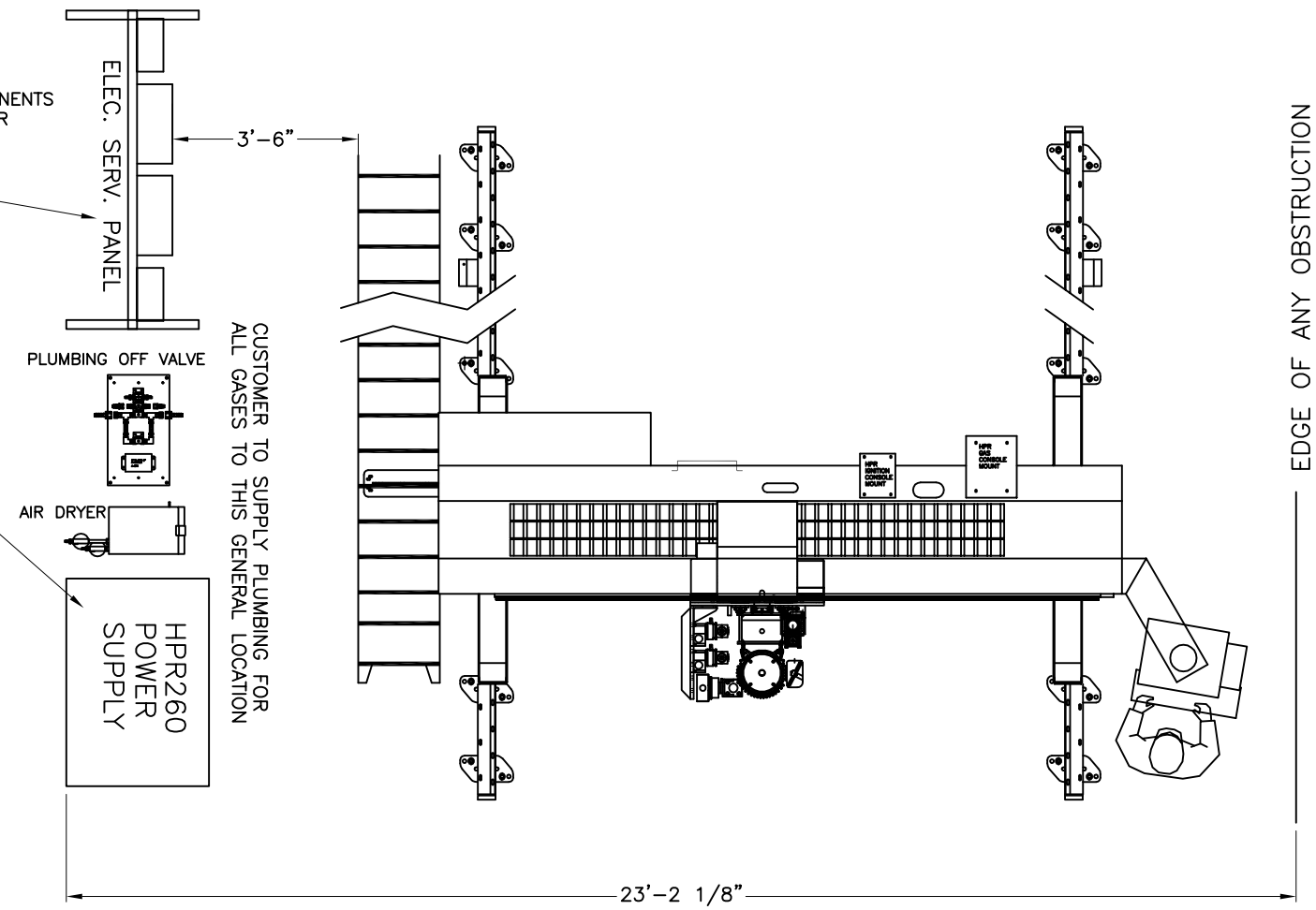

ALL DIMENSIONS ARE APPROXIMATED. DUE TO ASSEMBLY AND INSTALLATION PROCEDURES, ANY FINAL DIMENSION COULD VARY SLIGHTLY. IF FOR ANY REASON ANY DIMENSION MUST BE HELD TIGHT, THE CUSTOMER MUST NOTE IT ON THE APPROVAL.

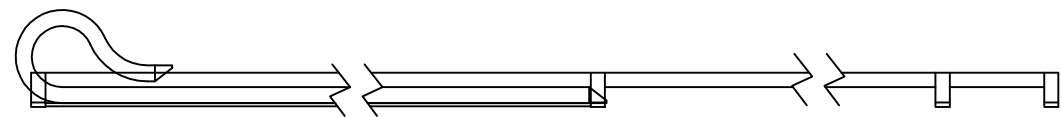
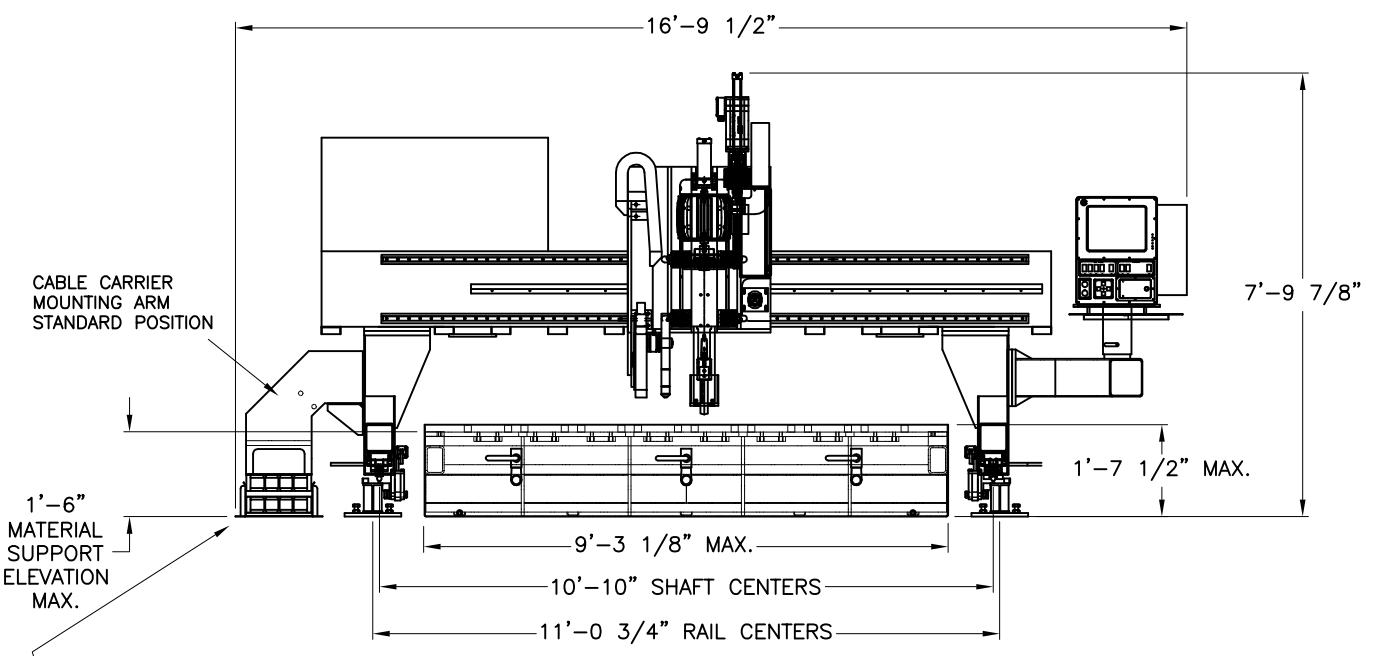

APPROXIMATE SIDE VIEW & PLACEMENT OF SERVICE CABLE MANAGEMENT

REV	DESCRIPTION	BY	DATE

© CONTROLLED AUTOMATION, INC.  
BRYANT, ARKANSAS

TITLE: 8'X34' BTD LAYOUT  
General Machine layout

SCALE: NTS	DATE: 4/23/08	JOB NUMBER:
DRAWN BY: JAR	REF. DWG.:	DRAWING NUMBER: REV: